

SW2015

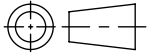

Revision level			Revision Record	Changed	Date	Approved	Date
Drawing	State	Part					
07.1	Design Release	-	SEE ECN# 013976	GAL	7/31/2017	MHT	7/31/2017

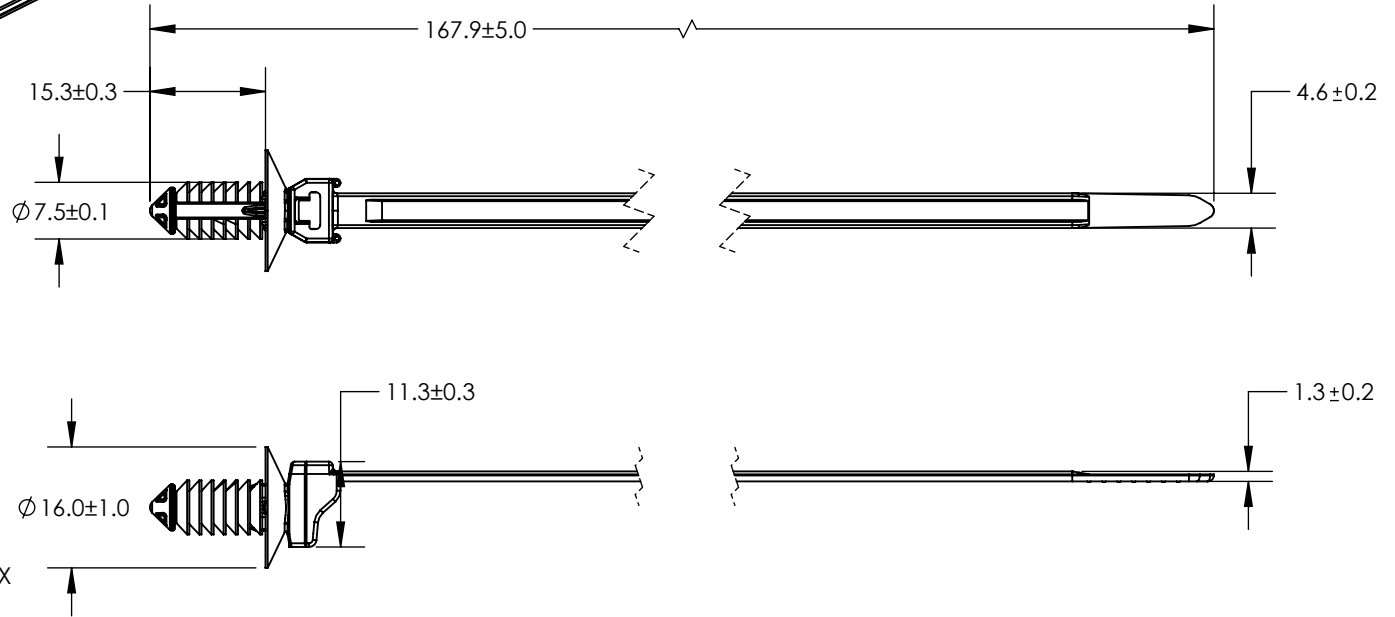
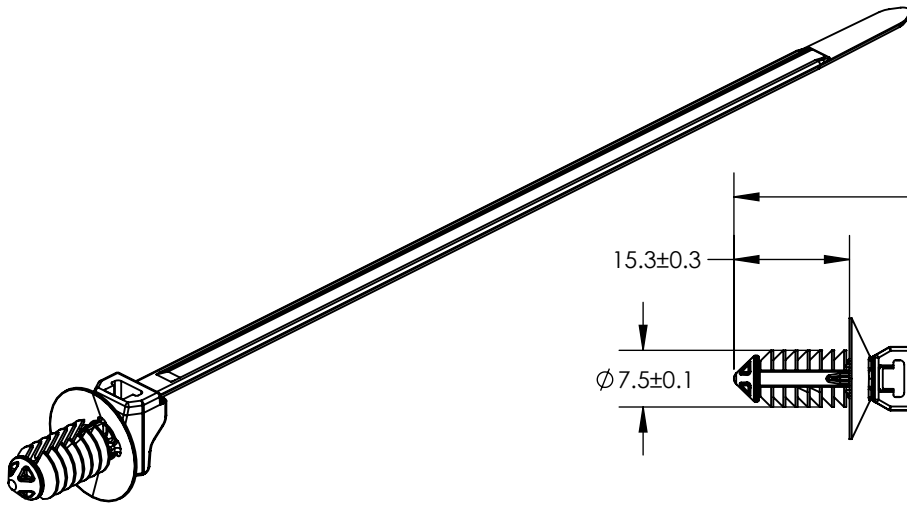

REFERENCE:

PERFORMANCE REQUIREMENTS:

1. FIR TREE PUSH IN FORCE: 45 NEWTONS (10 LBS) MAX IN THE APPLICABLE NOMINAL HOLE SIZE AND A PLATE THICKNESS OF 1.8mm.
2. FIR TREE PULL OUT FORCE: 110 NEWTONS (25 LBS) MIN IN THE APPLICABLE NOMINAL HOLE SIZE AND A PLATE THICKNESS OF 1.8mm.
3. SHEET METAL THICKNESS RANGE: 0.60mm - 8.25mm
4. APPLICABLE HOLE SIZES:
 - A. 6.5mm +/- 0.4mm
 - B. 6.35mm +/- 0.25mm HEX
5. CABLE TIE MIN. LOOP TENSILE STRENGTH: 225 NEWTONS (50 LBS) MIN
6. BUNDLE RANGE: 1.0mm TO 35.0mm
7. MAXIMUM PERCENT REGRIND PERMISSIBLE: 25%
8. MAX ALLOWABLE FLASH OR MISMATCH TO BE: 0.4mm



TYPE NUMBER	MATERIAL	COLOR
T50SOSFT6.5LG-E4	PA66HIRHS	BLACK
T50SOSFT6.5LG-E4	PA66HIRHS	NATURAL
T50SOSFT6.5LG-E4	PA66HS	GRAY
T50SOSFT6.5LG-E4	PA46	BROWN

Material SEE CHART	Units: millimeters	The copyright of this drawing is reserved by HellermannTyton. It is issued on condition that it is not reproduced, copied, or disclosed to a third party, either wholly or in part, without the consent of HellermannTyton.	Drawn	GAL	9/7/16	Article/Type-No SEE CHART	Scale	1:1	
	Dimension without tolerances details to: .xxx = ±.013 .xx = ±.13 .x = ±.3 None = ±.8 ∠ = ±0.5°		Approved	GGG	9/7/16		Title	T50SOSFT6.5LG-E4OUTSIDE SERRATED WITH 6.5mm FIR TREE	Project Number PRP 16-1353
	Dimension Formatted mm/[in]		HellermannTyton			Drawing-No	16-1353-021-CSU	Production : Phase	Format AH
			w	m		Sheet	1/1		